



Cleveland Controls
Division of UniControl Inc.

Model
AFS-460

ADJUSTABLE SET POINT AIR PRESSURE SENSING SWITCH WITH MANUAL RESET

APPLICATION

The **Model AFS-460** is a general purpose proving switch designed to require manual operator reset following actuation. It can be used to sense positive, negative, or differential air pressure in HVAC and Energy Management applications which require operator interface.

General Description & Operation

The plated housing contains a diaphragm, a calibration spring and a snap-acting SPST-NC switch with manual reset button.

The sample connections located on each side of the diaphragm accept 0.25" OD metallic tubing via the integral compression ferrule and nut.

An enclosure cover protects the operator from accidental contact with the live switch terminal screws and the set point adjusting screw. The enclosure cover accepts a 0.5" conduit connection.



MOUNTING (SEE FIGURE 1)

Select a mounting location which is free from vibration. The **AFS-460** must be mounted with the diaphragm in any vertical plane in order to obtain the lowest specified operating set point. Avoid mounting with the sample line connections in the "up" position. Surface mount via the two 3/16" diameter holes in the integral mounting bracket. The mounting holes are 3-7/8" apart.

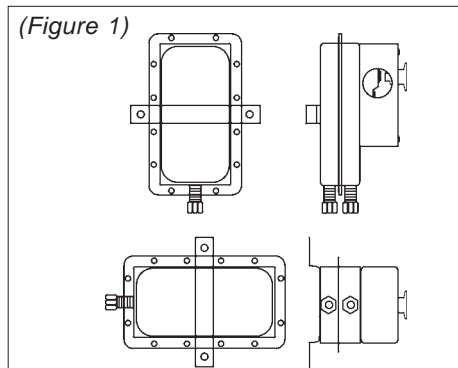

AIR SAMPLING CONNECTION (SEE FIGURE 2)

The **AFS-460** is designed to accept firm-wall sample lines of 1/4" OD tubing by means of ferrule and nut compression connections. An optional 1/4" adapter, suitable for slip-on flexible tubing is available: order part number 18311. For sample lines of up to 10 feet, 1/4" OD tubing is acceptable. For lines up to 20 feet, use 1/4" ID tubing.

For lines up to 60 feet, use 1/2" ID tubing. Locate the sampling probe a minimum of 1.5 duct diameters downstream from the air source. Install the sampling probe as close to the center of the airstream as possible. Refer to Figure 2 to identify the high pressure inlet (H) and the low pressure inlet (L). Select one of the five application options listed on page 2, and connect the sample lines as recommended.

POSITIVE PRESSURE ONLY: Connect the sample line to inlet H; inlet L remains open to the atmosphere.

NEGATIVE PRESSURE ONLY: Connect the sample line to inlet L; inlet H remains open to the atmosphere.

TWO NEGATIVE SAMPLES: Connect the higher negative sample to inlet L. Connect the lower negative sample to inlet H.

TWO POSITIVE SAMPLES: Connect the higher positive sample to inlet H. Connect the lower positive sample to inlet L.

ONE POSITIVE AND ONE NEGATIVE SAMPLE: Connect the positive sample to inlet H. Connect the negative sample to inlet L.



Cleveland Controls
DIVISION OF UNICONTROL INC.
1111 Brookpark Rd
Cleveland OH 44109

Tel: 216-398-0330

Fax: 216-398-8558

Email: sales HVAC@unicontrolinc.com

Web page: <http://www.clevelandcontrols.com>

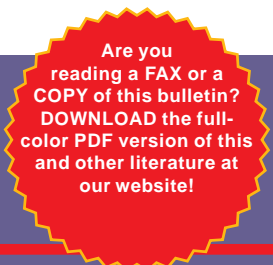

(Figure 2)

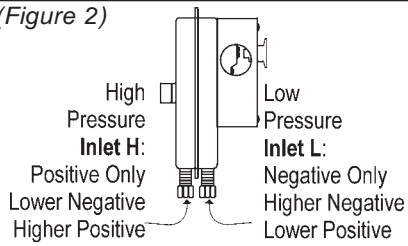

(Figure 3)

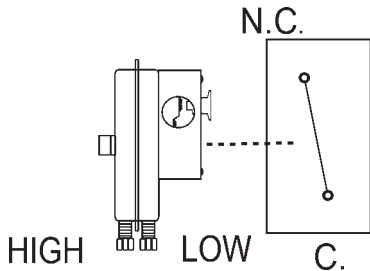

(Figure 4)

To prove excessive or insufficient air flow or pressure:

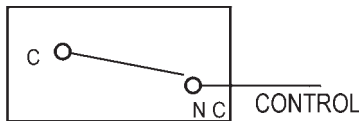

ELECTRICAL CONNECTIONS

(SEE FIGURE 3)

Before pressure is applied to the diaphragm, the switch contacts will be in the normally closed (NC) position.

The snap switch has screw top terminals with cup washers. Wire alarm and control applications as shown in **Figure 4**.

FIELD ADJUSTMENT

The adjustment range of an **AFS-460** Air Switch is $0.4" \pm 0.02"$ w.c. to $12.0"$ w.c. To adjust the set point, turn the adjusting screw counterclockwise until motion has stopped. Next, turn the adjusting screw four complete turns in a clockwise direction to engage the spring. From this point, the next ten turns will be used for the actual calibration. **Each full turn represents approximately 1.16" w.c.**

Please note: To properly calibrate an air switch, a digital manometer or other measuring device should be used to confirm the actual set point.

SPECIFICATIONS

MODEL AFS-460 AIR PRESSURE SENSING SWITCH WITH MANUAL RESET FEATURE

Mounting Position (in order to meet lowest operating specifications): Mount with the diaphragm in any vertical plane.

Set Point Range:

$0.40 \pm 0.06"$ w.c. to $12.0"$ w.c.

Field Adjustable "Operate Range":

$0.46"$ w.c. to $12.0"$ w.c.

Field Adjustable "Release Range":

$0.46"$ w.c. to $11.2"$ w.c.

Approximate Switch Differential:

Progressive, increasing from approximately

$0.06 \pm 0.01"$ w.c. at minimum set point, to approximately $0.8"$ w.c. at maximum set point.

Measured Media: Air, or combustion by-products that will not degrade silicone.

Maximum Pressure: $\frac{1}{2}$ psi (0.03 bar)

Life: Exceeds UL-recognized mechanical endurance test of 6,000 cycles minimum at 0.5 psi maximum pressure each cycle and at maximum electrical load.

Electrical Rating: @ 60 Hz.

15 amp 125, 250, or 277 VAC

$\frac{1}{4}$ hp 125 V AC, $\frac{1}{2}$ Hp 250 VAC,

$\frac{1}{2}$ amp 125 V DC,

$\frac{1}{4}$ amp 250 V DC.

Contact Arrangement:

SPST-NC (manual reset).

Electrical Connections:

Screw top terminals with cup washers. **Conduit Opening:** $\frac{7}{8}"$ diameter opening accepts $\frac{1}{2}"$ conduit.

Sample Line Connectors: Male, externally threaded $\frac{7}{16}"$ 24 UNS 2A thread, complete with nuts and self-aligning ferrules.

Sample Line Connections: Connectors will accept $\frac{1}{4}"$ OD rigid or semi-rigid tubing.

Approval and Recognition:

UL, CSA, CE.

Shipping Weight:

1.2 lbs.

Accessories:

- P/N 18311 Slip-on $\frac{1}{4}"$ OD Tubing Adapter, suitable for slipping on flexible plastic tubing.
- Sample line probes.
- Orifice plugs (pulsation dampers).

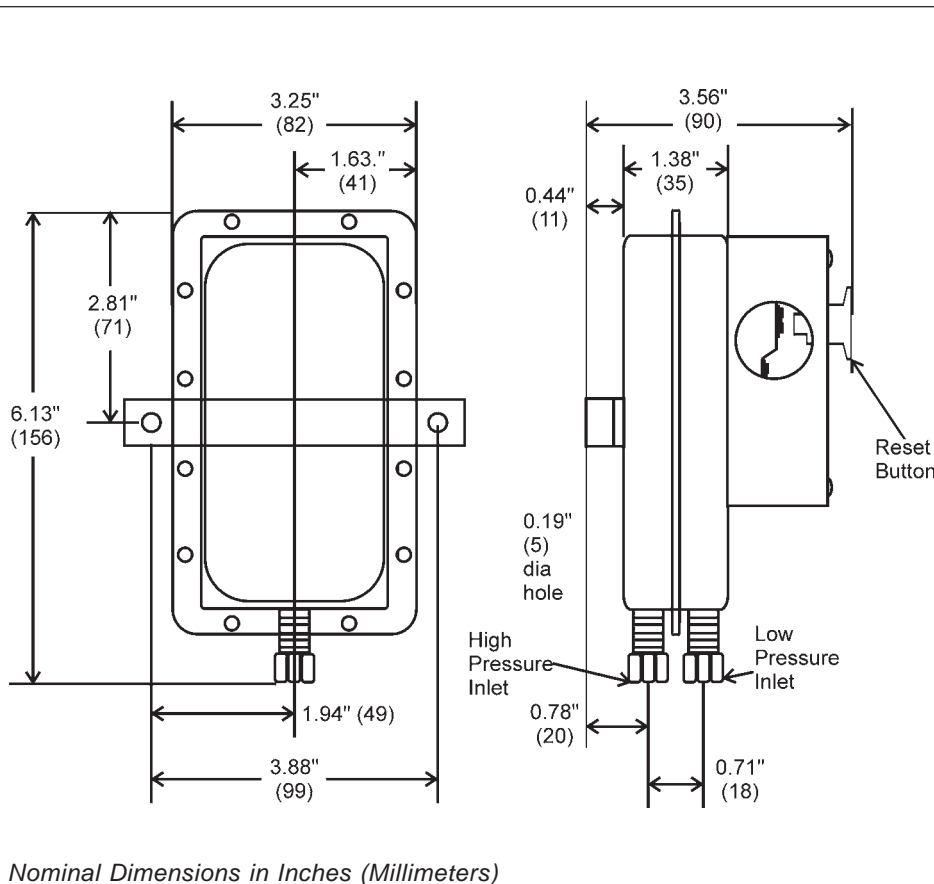

Nominal Dimensions in Inches (Millimeters)