

Model C-07200-A0 MANUAL/AUTO STATION

The Hays Cleveland Model C-07200-A0 MANUAL/AUTO STATION interfaces between a final control element and the automatic output of an upstream controller. Operator-adjustable manual outputs are available in the manual mode. Manual/Auto Stations provide smooth transfer between automatic and manual modes, and complete remote operation of a control loop in either mode.

Basic Station

In the automatic mode, this station receives and passes the control signal to the final element. When in the manual mode, the station allows full manual operation.

Ratio Station

The ratio control permits the operator to adjust the input/output relationship so that the output will be a percentage of the input. On 7261 models, the output can be any percent of input from 90% up to 110%. On 7271 models, the output can be any percent of input from 100% down to 50%.

OPERATION

The Hays Cleveland Model C-07200-A0 MANUAL/AUTO STATION receives a conditioned or unconditioned control signal from a master or other control device, adds manual/automatic station capability, and retransmits that signal to a final or intermediate element. Front-panel-adjustable ratioing of input to output is available by order option. Front panel digital indication is of measured position, typically from a 1000-ohm slidewire in the positioned element. This position signal is also used as a 1-5 v DC retransmitted signal to another controller or another positioning M/A station.



A typical use for these units is as positioning control stations. A master pressure controller supplies a 1-5 v DC master loading signal output simultaneously to three Model C-7211-230-00A Boiler Sub-Master Fuel Valve M/A Stations. These are fuel valve positioner controllers with 117 v AC switched output to an electric actuator that has a single 1000-ohm position slidewire. The measured fuel valve position signal in each of the above Boiler Sub-Masters is retransmitted to a Model C-7211-230-00A (non-ratio), C-7261-230-00A (ratioing) forced draft air station with 117 v AC switched output to forced draft air electric actuators with 1000-ohm slidewires.

Alternately, the above forced draft air C-7211 or C-7261-230-00A could be replaced by a C-7211 or C-7261-210-00A, which are non-ratioing and ratioing versions with 4-20 ma outputs. These might be used for variable speed drives on the forced draft air fan.

Another version is available with switched 117 v AC input that can only be used with the switched 117 v AC output option.

SPECIFICATIONS

- Power:** 120 v AC 50/60 Hz., .05a
- Isolation:** 300 v lines to case
- Input Signals & Impedances (Analog Input Models Only):**
 - 4-20 ma, 250 ohms
 - 1-5 v, 100K ohms
- Output Signal Range (Analog Output Models Only):**
 - 4-20 ma, 750 ohms (max)
 - 1-5 v
- Manual Control:** 10 turns produce 0 to 100% full-scale output.
- Ratio Control (Ratio Models Only):** Two modes available: Input x0.5 to x1; Input x0.9 to 1.1
- Ambient Temperature:** 40 to 120F (5 to 50C)
- Output Load:** 0.1 A (min), 1.0 A (max), 120 v AC 1ph.
- Dead Band Range (Switched Output Models Only):** 2-6% of input range
- Requirements:**
 - Active Range: 60% minimum
 - Resolution: 5% of active range, minimum
 - Resistance: 135 to 5000 ohms
- Connections:** Terminal strip
- Enclosure:** 18-gauge plated steel
- Mounting:** Panel
- Shipping Weight:** 6 lbs.

Specifications Subject to Change

HOW TO ORDER

The basic catalog number for the **Hays Cleveland Model C-07200-A0 Manual/Auto Station** is shown below. Replace suffixes AA through E with the desired selections from the table below.

C-072AA-B-CC-DD-E

Typical Examples: The code for a 117 v AC switched output fuel valve manual/auto station with a 1-5 v DC input from a master pressure controller is C-07211-230-00-A. For use with an AC20 or AC30 controller, use C-07211-130-01. The code for a 117 v AC switched output forced draft manual auto station with a 1-5 v DC retransmitted slidewire position

input from a 117 v AC fuel valve positioner is C-07211-230-00-A. The code for a 4-20 ma variable speed forced draft manual/auto station with a 1-5 v DC retransmitted slidewire position input from a fuel valve positioner is C-07211-210-00-A.

AA. Function of Station:

- Basic [Standard] (AA=11)
- Ratio $\pm 10\%$ [gain = x0.9 to 1.1] (AA=61)
- Ratio + 0%, -50% [gain = x1.0 to 0.5] (AA=71)

B. Input Signal:

- 4-20 ma DC (B=1)
- 1-5 v DC (B=2)
- Switched 117 v AC [C-07211-330-00A only] (B=3)

CC. Output Signal:

- 4-20 ma DC (CC=10)
- 1-5 v DC (CC=20)
- Switched 117 v AC (CC=30)

DD. Options:

- None (DD=00)
- Switch contact for bumpless transfer [used with AC20 and AC30 controllers – see C-07000-AC] (DD=01)

E. Current Model Designation: B

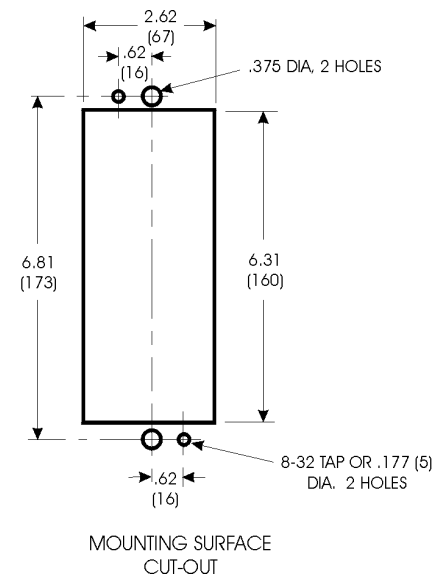
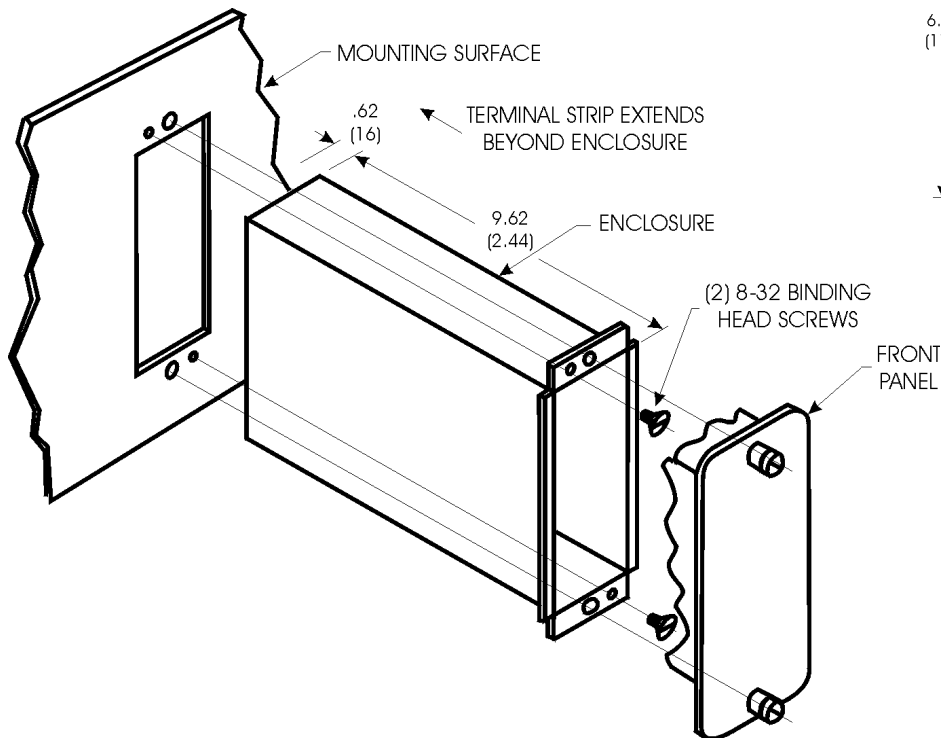

Are you reading a FAX or a COPY of this bulletin? DOWNLOAD the full-color PDF version of this and other literature at our website!

Visit us on the World Wide Web at www.hayscleveland.com

Hays Cleveland Div. of UniControl Inc.
1903 South Congress Avenue
Boynton Beach FL 33426
Telephone: 561.734.9400
Fax: 561.734.8060
Email: salescombustion@unicontrolinc.com

Hays Cleveland Div. of UniControl Inc.
1111 Brookpark Road
Cleveland OH 44109
Telephone: 216.398.4414
Fax: 216.398.8558
Email: salescombustion@unicontrolinc.com